

Section 8—Meters and Meter Sockets

8-1 Meters and Meter Sockets

8-1a Customer/Contractor

- ☑ Consult with the company for service greater than 400 amperes or 600 volts.
- ☑ Provide a company-approved meter socket or meter transformer enclosure as part of the service equipment for multi-socket panel assemblies or prewired combination meter and service equipment pedestals. This is subject to advance approval by the company. The customer is responsible for maintenance and repair of this equipment.
- ☑ Install metering transformers for service above 400 amperes, in most cases.
- ☑ Contact the company to discuss the service equipment requirements and arrangements.
- ☑ Install Number 4 AWG copper grounding electrode conductor from CT meter sockets and all three-phase, self-contained meter sockets to an exposed five-eighths-inch by eight-foot driven ground rod.
- ☑ Do not use meter mounting boxes as junction boxes.

Note: Customer devices cannot be installed on the line (supply) side of any meter except:

- Those installations consisting of more than six meters on a single service entrance.
- Self-contained meters for services above 240 volts (including all 277 volt and 480 volt installations and above).

For these two exceptions the customer disconnect must be installed on the line side of the meters.

- ☑ Connect metering on the line side of the service equipment, except as Noted in this section. Mechanical/high pressure connections may be allowed in metering equipment as specified by the company.

Unauthorized jumpers are not allowed in meter boxes; no lubricant is allowed to be applied to any meter socket jaws. The company must approve all exceptions.

- ☑ Ensure that metering enclosures greater than 400 amperes serving more than one service entrance have a disconnecting device capable of disconnecting all loads served by that meter.

- ☑ Ensure that there is a minimum of four feet of clearance in front of the meter.

Note: All meter sockets and enclosures must comply to the latest revisions of ANSI/UL 414, ANSI CI 2, NEMA 250 and must carry the UL label. They must be of ringless design with bypass horns and have a sealing mechanism, which allows the cover to be sealed.

8-1b Company

- ☑ Provide and connect all meters and associated equipment required for billing purposes.
- ☑ Provide the equipment that is to be installed by the customer.
- ☑ Connect all power and control equipment.
- ☑ Seal all meter facilities and all points of access to unmetered wiring on customer's premises.
- ☑ Refuse to connect the service if the customer installation is defective, or is in violation of company or NEC standards. Unauthorized jumpers are not allowed in meter boxes; no lubricant is allowed to be applied to any meter socket jaws. The company must approve all exceptions.

8-2 Meter Location

General

It is in the interest of both the customer and the company that a suitable and adequately protected meter location be provided to ensure accuracy and to facilitate installation, reading, and maintenance.

All metering equipment must be readily accessible to company personnel at all times.

Meter Separation

The company requires that the meter location for all new installations for residential service be installed outside. If the meter is indoors, the meter must be relocated to the outside of the building structure for rewiring or upgrading of services.

Meters supplied from new underground residential systems must be located within five feet of the corner of the building nearest the service point from which the service will originate.

At locations where it is necessary to install four or more meters adjacent to each other, the meters may be installed in a room provided for this purpose. Refer to **Multiple Metering Installations, Section 8-6, 8-9**, for specific service requirements.

SECTION 8

METER SEPARATION

SEPARATION BETWEEN A GAS METER/REGULATOR AND AN ELECTRIC METER AND/OR METERS MUST BE 5 FEET MINIMUM AND 6 INCHES ON THE OUTLET SIDE OF THE GAS METER BAR.

THERE MUST BE 12 INCHES ON ALL SIDES AND 4 FEET OF CLEAR SPACE, SUITABLE FOR A WORKER, IN FRONT OF EACH METER PANEL. ACCESS MUST BE MAINTAINED TO THE METER AND/OR METERS AT ALL TIMES.

INSTALLATIONS MUST COMPLY WITH ALL APPLICABLE CODES AND REGULATIONS.

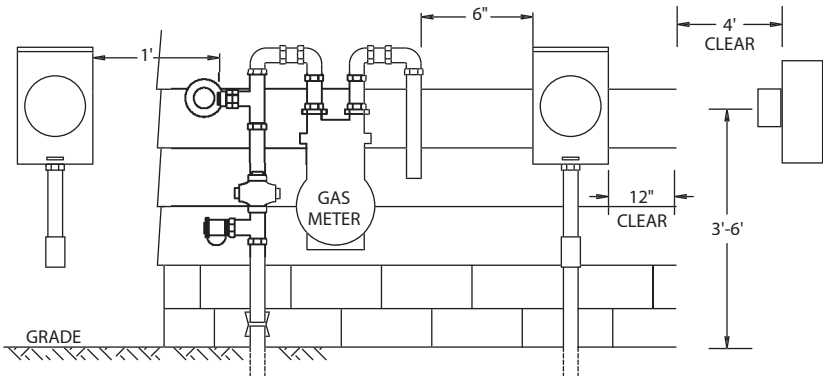

Fig. 33

The metering equipment must be readily accessible and installed in locations free from vibration, dust, and corrosive atmospheres.

When the service is supplied from transformer vaults, meters must be located outside such vaults.

For customer load center pole installations, an overcurrent disconnect device may be required. For these types of situations consult company engineering.

8-3 Meter Installations

All metering equipment, including service pedestals, must be adequately supported, securely fastened, and must be in a level and plumb position. Meter sockets must be installed such that the horizontal centerline of the meters will be no more than six feet, or less than three feet, above finish floor or final grade. Ensure that there is a minimum of four feet of clearance in front of the meter.

8-4 Single-Phase (Refer to figures 34-37)

8-5 Overhead and Underground Meters

200 AMP OH METER BOX

Fig. 34

SERVICE APPLICATION**200 AMP OH (ALSO 100 + 150 AMP)**

1-PHASE, 3-WIRE 120/240V

*120/208V

FOR 1-PHASE RESIDENTIAL OR NON RESIDENTIAL APPLICATIONS

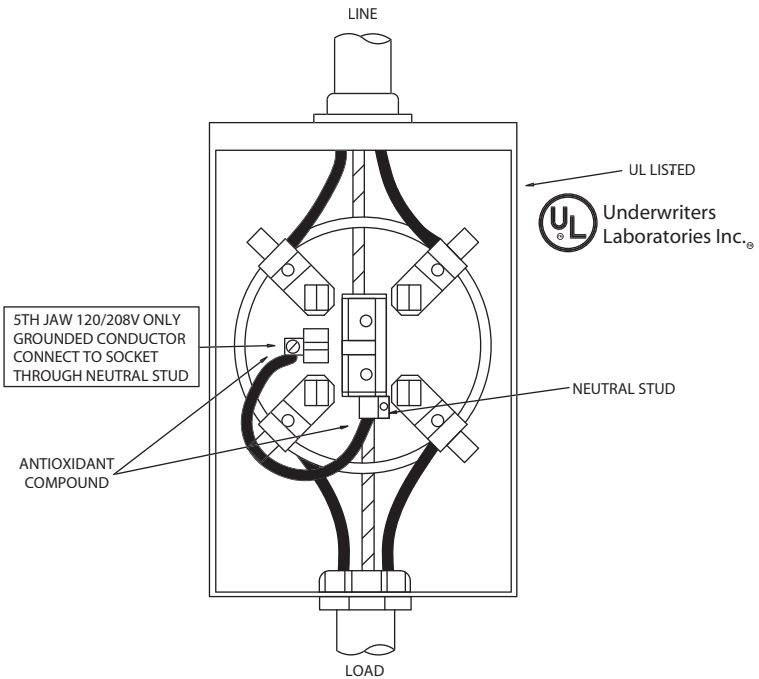

*FOR 1-PHASE, 3-WIRE, 120/208V APPLICATIONS, A COMPATIBLE 5TH JAW MUST BE INSTALLED IN THE METER SOCKET AT THE 6 OR 9 O'CLOCK POSITION. WHEN USING A 5TH JAW CONFIGURATION, THE 5TH JAW MUST BE MANUFACTURER APPROVED FOR THE METER SOCKET IN WHICH IT IS INSTALLED AND BE INSTALLED ACCORDING TO MANUFACTURER SPECIFICATIONS.

SECTION 8

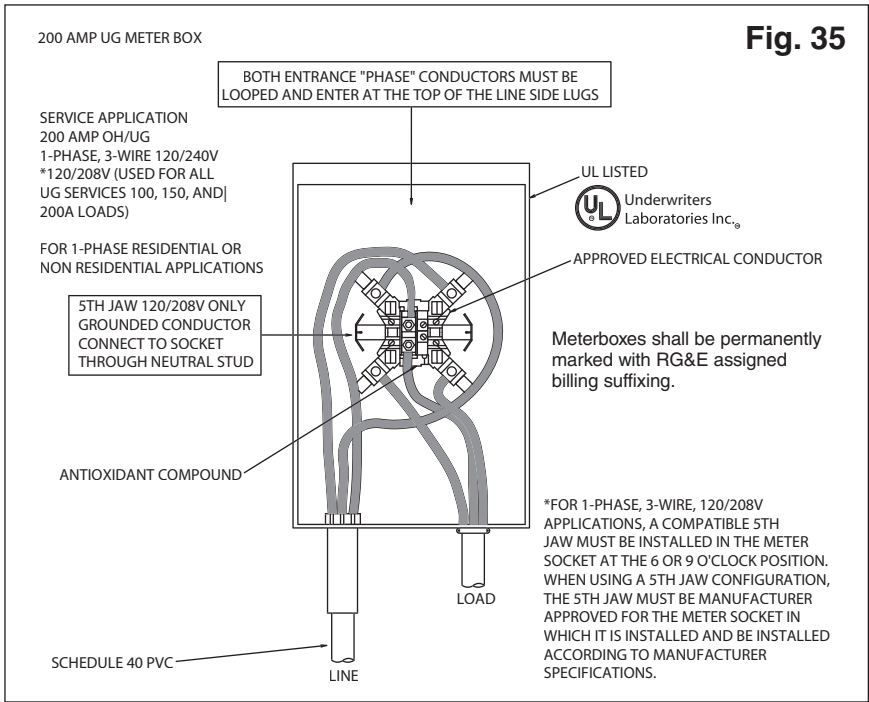

8-6 Multiple Gang and 320 Amp Meter

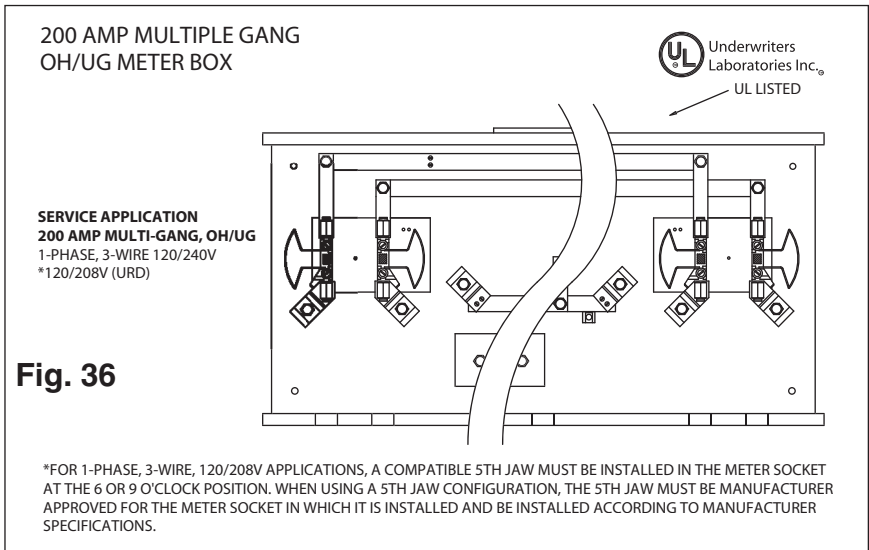

320 AMP OH/UG METER BOX

Exception to looping lineside conductor.

Fig. 37

SERVICE APPLICATION
320 AMP OH/UG

1-PHASE, 3-WIRE 120/240V
 *120/208V (USED FOR ALL
 PARALLEL SERVICES UP
 TO 400 AMPS)

5TH JAW 120/208V ONLY
 GROUNDED CONDUCTOR
 CONNECT TO SOCKET
 THROUGH NEUTRAL STUD

DIMENSIONS: 34"H x 18"W x 6"D

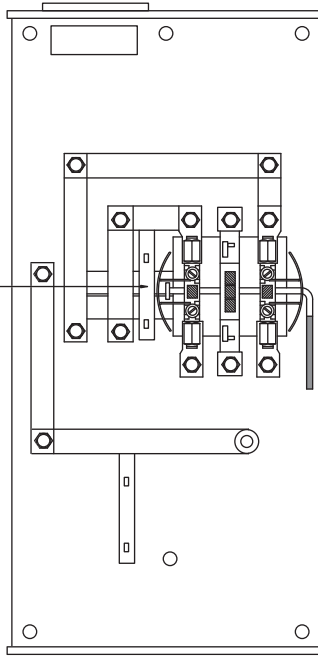

UL LISTED

Underwriters
Laboratories Inc.,

*FOR 1-PHASE, 3-WIRE, 120/208V APPLICATIONS, A COMPATIBLE 5TH JAW MUST BE INSTALLED IN THE METER SOCKET AT THE 6 OR 9 O'CLOCK POSITION. WHEN USING A 5TH JAW CONFIGURATION, THE 5TH JAW MUST BE MANUFACTURER APPROVED FOR THE METER SOCKET IN WHICH IT IS INSTALLED AND BE INSTALLED ACCORDING TO MANUFACTURER SPECIFICATIONS

8-6a Customer/Contractor

- ☑ Provide, install, own, and maintain meter socket equipment approved by the company where electric service is less than 600 volts and the current is less than 400 amperes.
- ☑ Ensure that all meter sockets and enclosures comply with the latest revisions of ANSI/UL 414, ANSI C12.7, NEMA 250, and carry the UL label. Also, they **must be of ringless design with bypass horns and have a sealing mechanism which allows the cover to be sealed.**
- ☑ Ensure when using a 5th jaw configuration that the 5th jaw is manufacturer approved for the meter socket in which it is installed and must be installed according to the manufacturer's specifications at the six or nine o'clock position.

SECTION 8

- ☑ Provide and install approved service entrance cable or conductors.
- ☑ Provide and install a watertight connector where a cable entry is made in the top of a meter box.
- ☑ Purchase and supply any meter hubs and cover plates.
- ☑ Ensure that there is a minimum of four feet of clearance in front of the meter.

8-6b Company

- ☑ Spot new meter locations for nonresidential service.

8-7 Three-Phase and Metering Transformers 3-Phase 4-Wire WYE 480/277v Self-Contained Meter Box

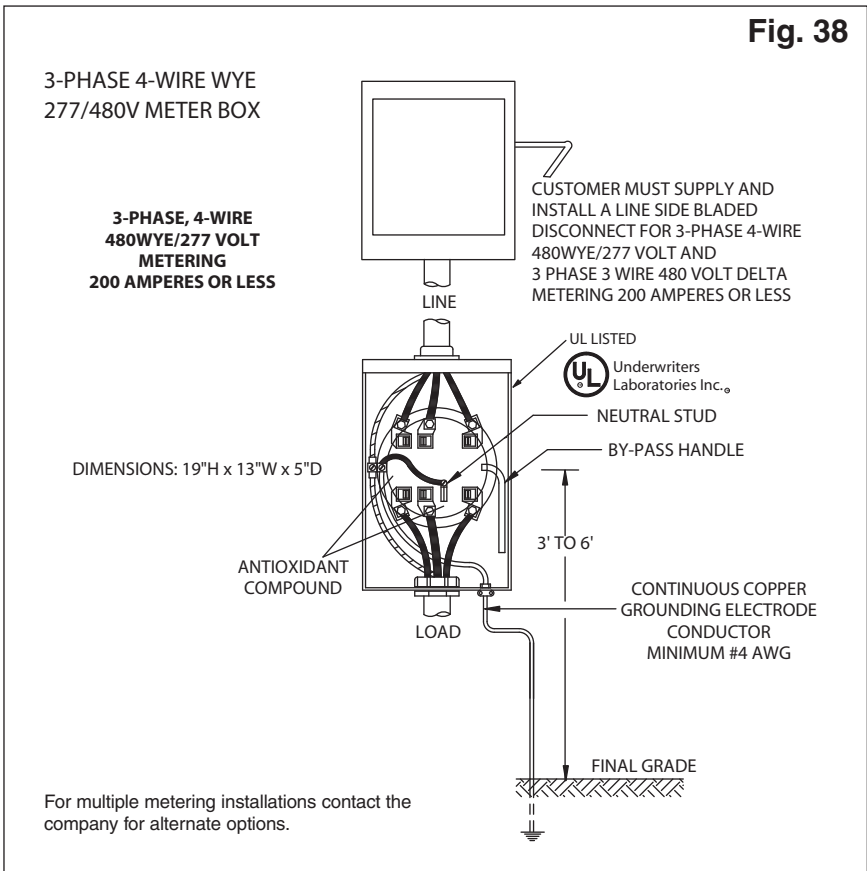

3-Phase 4-Wire Self-Contained Meter Box

3-PHASE 4-WIRE DELTA OR WYE
120/240V OR 120/208V METER BOX

Fig. 39

3-PHASE, 4-WIRE DELTA 120/240 VOLT, 120/208 VOLT
METERING 200 AMPERES OR LESS

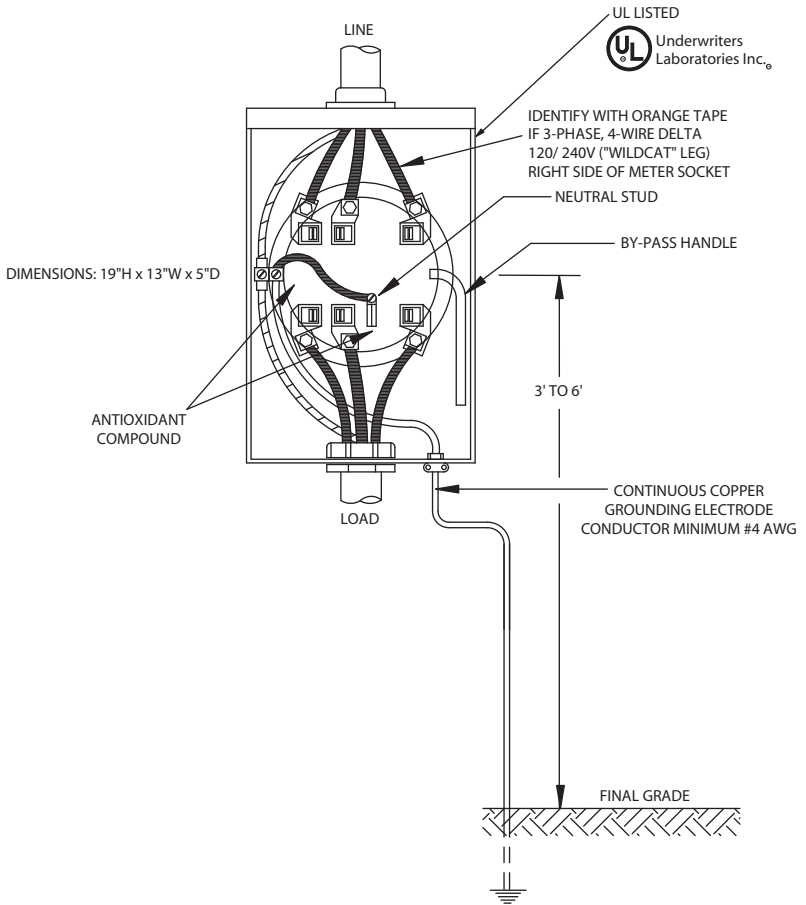

SECTION 8

3-Phase 3-Wire Delta 480v Self-Contained Meter Box

Fig. 40

3-PHASE 3-WIRE DELTA 480V METER BOX

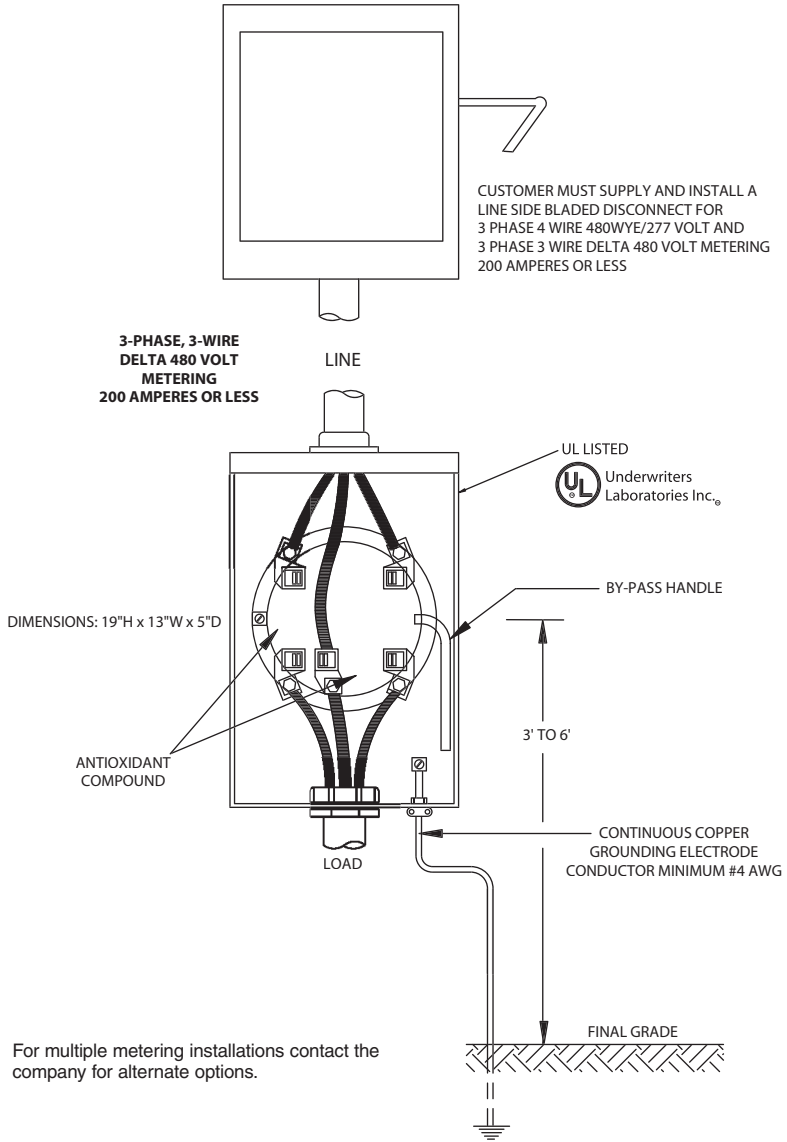

320 Amp 3-Phase 4-Wire OH/UG Meter Box

**320 AMP 3 PHASE 4 WIRE
OH/UG METER BOX**

SERVICE APPLICATION

320 AMP OH/UG
3-PHASE, 4-WIRE 120/240V
*120/208V OR 277/480V

UL LISTED
 Underwriters
 Laboratories Inc.,

DIMENSIONS: 34"H x 18"W x 6"D

IDENTIFY WITH ORANGE TAPE
 IF 3-PHASE, 4-WIRE DELTA
 120/ 240V ("WILDCAT" LEG)
 LEFT SIDE OF METER SOCKET

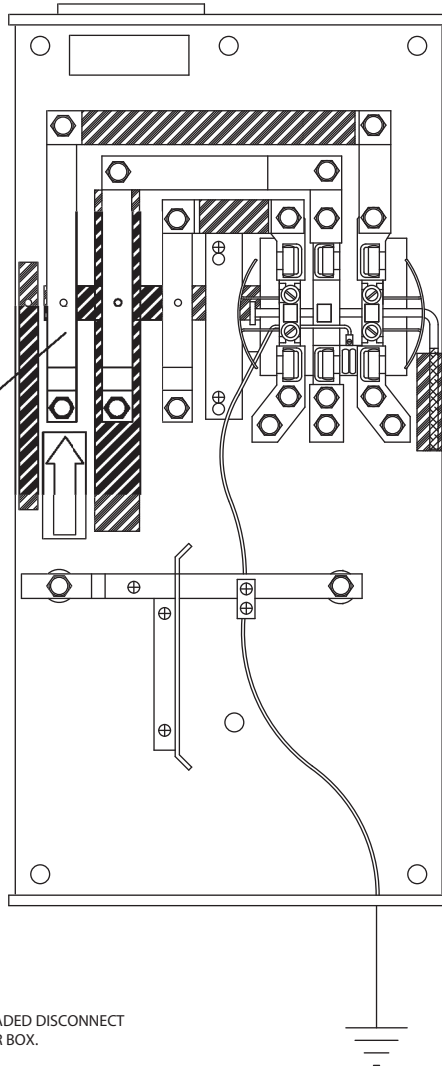

*ON 277/480 VOLT SERVICES, A BLADED DISCONNECT
 IS REQUIRED AHEAD OF THE METER BOX.

*IF THE CUSTOMER REQUESTS METERING IN THE PADMOUNT
 TRANSFORMER OR IN CUSTOMER SUPPLIED CT & VT CABINET,
 CONSULT THE MARKETING DEPARTMENT FOR ADDITIONAL COSTS.

Fig. 41

SECTION 8

8-7b Company

- ☑ Provide metering transformers.
- ☑ Install all meters and connect metering transformers, and associated equipment for commercial and industrial applications.

Note: In most cases, metering transformers are required for service greater than 400 amperes.

8-8 CT Metering

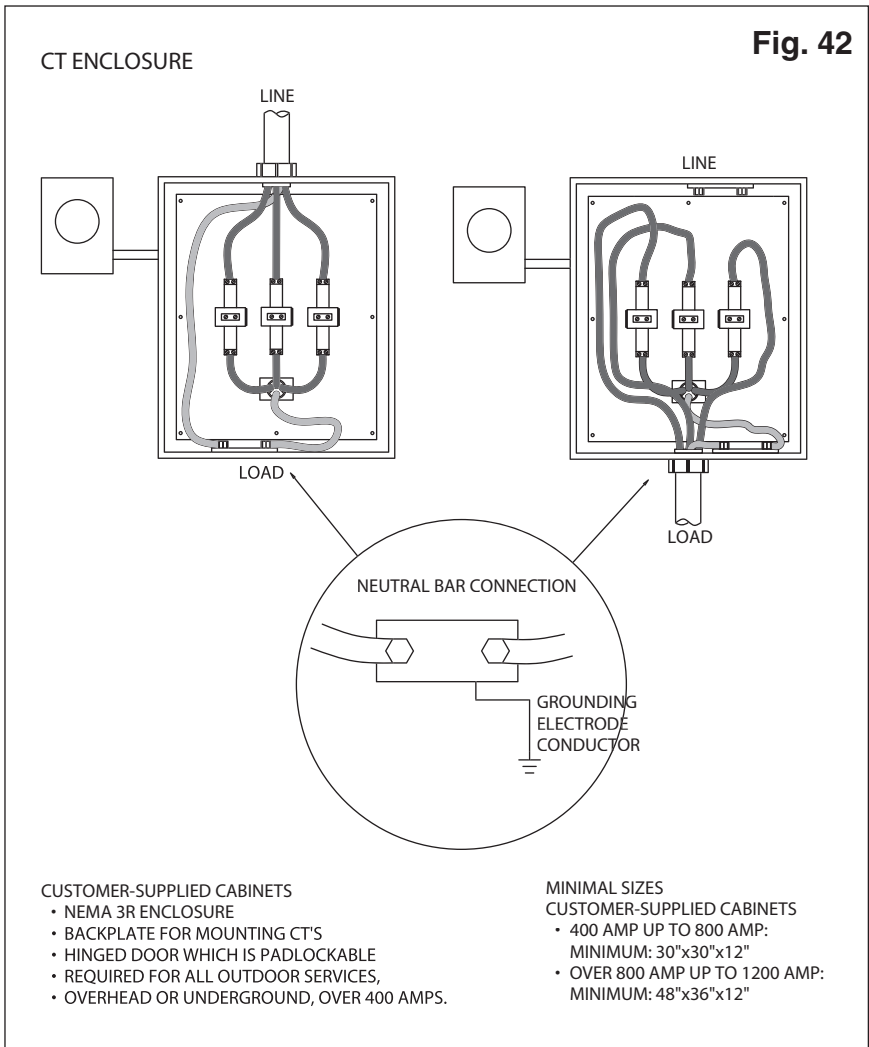

8–8a Customer/Contractor

- ☑ Contact the company to discuss the service equipment requirements and arrangements.
- ☑ Install Number 4 AWG copper grounding electrode conductor from CT meter sockets and all three-phase, self-contained meter sockets to an exposed five-eighths-inch by eight-foot driven ground rod.
- ☑ Provide and install conduit from the metering transformer enclosure to the meter location.
- ☑ Install metering wires provided by the company from the metering transformer enclosure to the meter location.
- ☑ Consult with the company when metering transformers are to be mounted in a vault, metal-enclosed switchgear, or on a switchboard.
- ☑ Provide a drawing of the proposed installation before proceeding.
- ☑ Provide communication facilities, when required.

8–8b Company

- ☑ Permit no meters or instruments other than its own to be connected to its metering transformer secondary.
- ☑ Mount the meter on the outside of padmounted transformers (commercial and industrial services only), if applicable.
- ☑ Supply meter control wire.
- ☑ Determine the size of the conduit and the number and size of the metering wires.
- ☑ Approve the switchgear prior to customer purchase when the company's metering transformers are to be installed in metal-enclosed switchgear owned by the customer. In this case, the company may have the transformers installed by either the customer or the switchgear manufacturer.

8–9 Multiple Meter Installations

At locations where it is necessary to install four or more meters adjacent to each other, the meters may be installed in a room provided for this purpose.

Meters for all customers in multiple-occupancy buildings must be grouped in a single location and there must be adequate work-space clearance (a minimum of four feet).

SECTION 8

8-9a Customer/Contractor

- ☑ Ensure that all multiple meter installation of customer-supplied, stacked, or modular metering complies to the latest revision of ANSI/UL 414, ANSI C12.7, NEMA 250, and carries the UL Label. Also, they must be of ringless design and have a sealing mechanism which allows the cover to be sealed. Residential applications must have horn bypass. Three-phase and commercial applications must have lever bypass.

In multi-occupancy buildings of three or more stories, the customer may install unmetred conductors to a company-approved meter location on alternate floors. The installation must comply with the current requirements of the NEC, and other applicable codes. Disconnecting devices must be permanently marked to designate the floor levels controlled and located at the point of service entrance. The company is not responsible for the voltage level beyond the service entrance.

The company assigns the labeling (suffix) for markings. No meter will be installed by the company in those cases where the customer has not physically labeled the meter box (meter socket enclosures). For residential dwelling units, the meter supplies service to that dwelling unit only and must be properly identified.

8-10 Meter Pedestal

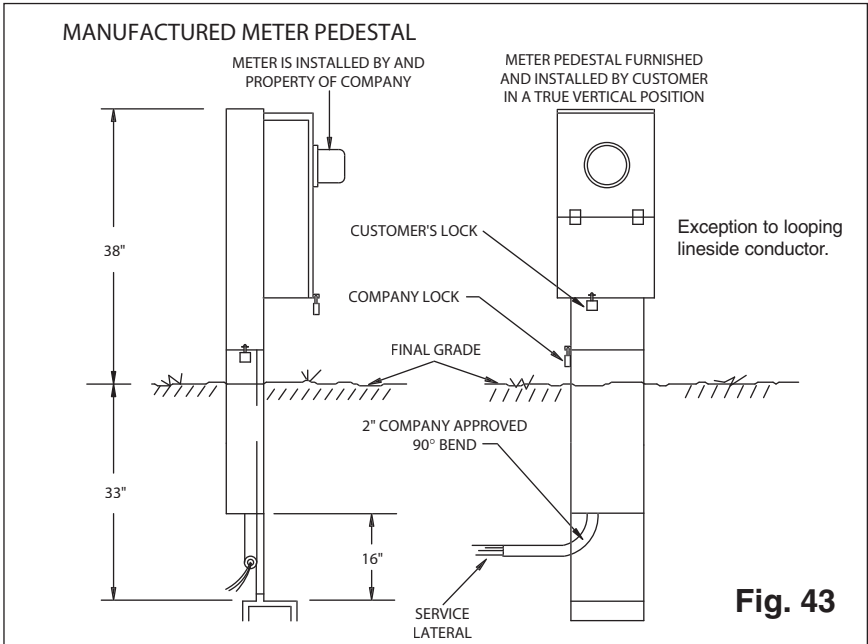

8-11 Wooden Type Pedestal

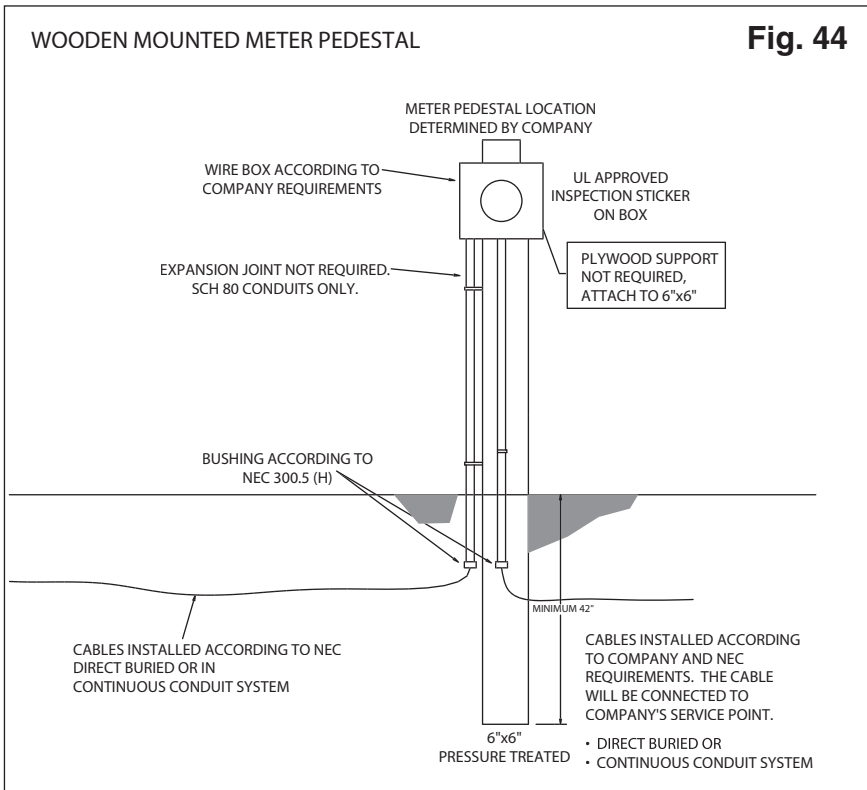

The customer provides and installs prewired combination metering and service equipment pedestals for underground service to mobile homes. All pedestals must conform to the latest revision of ANSI/UL 414, ANSI C 12.7, NEMA 250 and carry the UL label. They must be of ringless design with horn bypass and have a sealing mechanism which allows the cover to be sealed.

8-12 Special Equipment

The customer must pay the cost of the equipment and its installation when special and/or additional equipment is requested to furnish pulses in conjunction with demand-limiting control devices. The company assumes no responsibility for problems caused by the malfunction of this equipment.

SECTION 8

8–13 Metering Wiring

For overhead services, the preferred entry and exit wiring method of meter boxes is through the top and out the bottom.

Underground must be in and out of the bottom of the meter box; both entrance phase conductors must be looped and enter at the top of the line side lugs.

Approved antioxidant compound must be used.

8–14 Relocation

If changes are made by the customer making the existing meter or service equipment unsafe or inaccessible, the customer must make the changes and absorb the expense to correct this condition.

8–15 Unauthorized Use

The breaking of seals, tampering with meters, or unmetered wiring is prohibited by New York State Penal Laws, and **violators are subject to criminal penalties.**